



# Wieland Coaxial Heat Exchangers

Condenser and Evaporator with optimum counter-flow layout

Wieland coaxial heat exchangers are used as condensers (WKC) or as evaporators (WKE). Depending on the performance they consist of one or more thermal optimized inner tubes and one outer tube. The counter-flow layout ensures an optimum heat exchange.

## Coaxial Condensers WKC

Wieland Coaxial Condensers are normally used in applications which require high water temperatures in conjunction with the use of hot gaseous refrigerant. For a low-noise, non-vibration operation, dents are pressed into the jacket tube.

## Coaxial Evaporators WKE

These Coaxial Heat Exchangers are the preferred choice in applications where water needs to be cooled significantly. At the same time they also offer reliable superheating of the suction vapour, which is supported by the counter-flow layout. A low-noise operation is achieved by spacer rings in the jacket tube.

For the pre-selection of a Coaxial Heat Exchanger the details for condensation and evaporation listed in the table below or the online software ThermalS can be used.

<https://www.wieland.com/en/thermals>

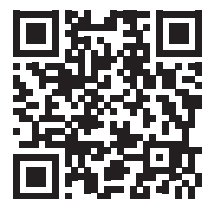

## Available Versions

### Coaxial Condensers WKC

Model	Number of inner tubes	Installation dimensions [mm]			Connection dimensions [mm]					Volume [l]		Weight appr. [kg]	Classification PED 2014/68/EU
					Refrigerant	Coolant				Refrigerant	Coolant		
		A	B	H	d <sub>1</sub> *	d <sub>2</sub> */d <sub>3</sub> *	d <sub>4</sub> **	a	h				
WKC 10	1	225	270	135	16	12.7	15.9	190	98	0.6	0.3	3.5	sound engineering practice
WKC 15	1	230	290	235	18	16.0	19.0	190	196	1.0	0.8	7.5	sound engineering practice
WKC 20	1	350	360	220	22	21.7	25.5	300	172	1.8	1.75	10.5	Category 1 Module A
WKC 45	4	520	530	225	35	28.0	31.9	445	152	3.7	2.9	21.0	Category 1 Module A

\* Internal soldering ends

\*\* External soldering ends

## Available versions

### Coaxial Evaporators WKE

Model	Number of inner tubes	Installation dimensions [mm]			Connection dimensions [mm]					Volume [l]		Weight appr. [kg]	Classification PED 2014/68/EU
					Heating medium	Refrigerant				Heating medium	Refrigerant		
		A	B	H	d <sub>1</sub> *	in d <sub>2</sub> *	out d <sub>3</sub> *	a	h				
WKE 10	1	330	325	130	16	13	13	290	94	0.8	0.4	4.1	sound engineering practice
WKE 16	2	340	390	190	28	22	22	290	140	1.8	0.9	8.1	sound engineering practice
WKE 24	3	435	465	175	28	18	18	380	122	2.4	1.3	11.1	sound engineering practice
WKE 44	5	605	600	220	35	28	28	530	150	4.9	2.9	24.7	Category 1 Module A

\* Internal soldering ends

For WKE 10 the fitting on the refrigerant side can be used as external soldering end d<sub>4</sub> with Ø16 mm (e.g. for tube Ø18 x 1 mm).

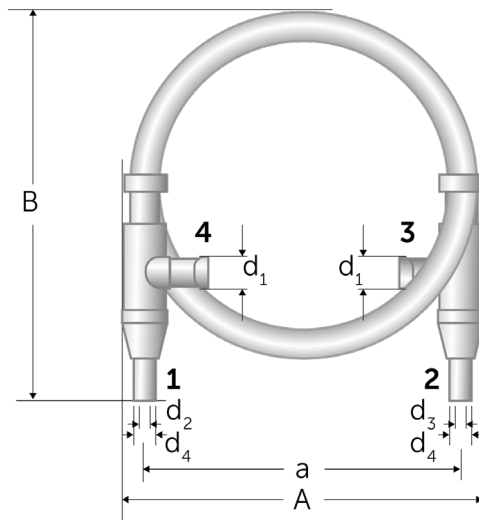
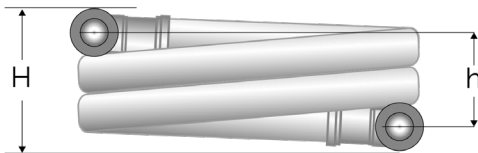

### Condenser WKC

- 1 Coolant outlet | e.g. heating water
- 2 Coolant inlet | e.g. heating water
- 3 Refrigerant outlet
- 4 Refrigerant inlet

### Evaporators WKE

- 1 Refrigerant outlet
- 2 Refrigerant inlet
- 3 Heating medium outlet
- 4 Heating medium inlet



## Customized Design

Individual coaxial heat exchangers are available with customized series. Suitable for additional performance range and the use with natural refrigerants and operating pressures higher than 35 bar. An individual design can be fitted to your construction requirements.

Contact us!

## Application

### Advantages

- High specific performance through optimized inner tubes
- Counter-flow
- Frost-proof
- Low fouling
- Long life
- Reversible operation possible

### Applications

- Heat pumps for hot water
- Chillers
- Cascade heat exchangers in multistage refrigeration systems
- Air conditioning and heating in marine applications

### Operating range

- Max. operating pressure: 35 bar (refrigerant side) 15 bar (fluid side)
- Max. operating temperature: –50 °C to +150 °C

### Assembly instructions

Coaxial heat exchangers should preferably be operated in counter-flow operation. The inner tubes as well as the jacket tube and brazed T-fittings are made of Cu-DHP.

**Condensers WKC** are installed so that the liquefied refrigerant is free to drain away to the bottom. The hot gaseous refrigerant enters the jacket space at the top, whereas the cooling medium (e.g. water) enters the inner tube(s). Coaxial condensers are also installed standing on the windings (winding axis horizontal). If an application requires several condensers to be connected in

parallel, then the tubing should be designed in such a way that each condenser can be supplied with even pressure on both the refrigerant side and the cooling medium side.

The routing of the hot-gas line should be installed avoiding any vibrations. This is normally achieved by installing vibration dampers (compensators). In order to avoid pulsating noises, we recommend installing a sound muffler between the compressor and the condenser. Please follow the manufacturer's instructions when installing these components.

The installation of **evaporators WKE** preferably allows the refrigerant to enter through the bottom connection. If several evaporators of the same size are to be connected in parallel, then it must be ensured that each evaporator is supplied with even pressure both on the refrigerant side and on the heating medium side.

For an approximation of the refrigerant capacity of the overall system following proportions of the refrigerant side volume should be used as an approximation: WKC: 30 %, WKE: 40 %

## Quality Assurance

Responsibility begins with a high standard of quality. As the first company for semi-finished products in Europe, we have been on the path to certified quality management since 1987.

Today, we have DIN EN ISO 9001:2015 certifications for all producing plants, and our testing laboratories in Ulm and Vöhringen are additionally accredited to DIN EN ISO/IEC 17025:2018.

## Pressure Equipment Directive

Coaxial heat exchangers correspond with the Pressure Equipment Directive 2014/68/EU. They are normally classified in the categories mentioned in the overview and are manufactured and supplied in accordance with the measures designated for this purpose. Operating conditions which exceed these specifications are subject to special requirements which should be agreed separately for each individual case.

## Performance overview

The specified values are based on our own measurements. They should be used as reference values only and apply under the described nominal conditions which conform as far as possible to the corresponding standards (e.g. EN 1117). Operating conditions which vary from these conditions may result in different values.

## Condensers WKC

Example: Refrigerant: R134a;  $t_c = 45\text{ °C}$ ;  $t_{sup} = \text{ca. } 65\text{ °C}$ ;  $\Delta t_{sub} = 4\text{ K}$

Coolant: water;  $w \approx 0,5$  bis  $2\text{ m/s}$

Type	$\dot{V}$	$\Delta p$	$Q_c$ R134a				$Q_c$ R404A/R507				$Q_c$ R410A			
$\Delta t_c$ [K]			7,0	10,0	15,0	20,0	7,0	10,0	15,0	20,0	7,0	10,0	15,0	20,0
Units	$\text{m}^3/\text{h}$	mbar	kW	kW	kW	kW	kW	kW	kW	kW	kW	kW	kW	kW
WKC 10	0.2	30	1.5	2.2	3.3	4.4	1.8	2.5	3.7	5.0	1.8	2.5	3.7	5.0
	0.4	91	2.2	3.1	4.6	6.2	2.5	3.5	5.2	7.0	2.5	3.5	5.2	7.0
	0.6	185	2.7	4.0	5.9	7.9	3.1	4.5	6.7	9.0	3.1	4.5	6.7	9.0
	0.8	311	3.3	4.8	7.2	9.7	3.8	5.5	8.2	11.0	3.8	5.5	8.2	11.0
	1.0	469	4.0	5.6	8.4	11.3	4.5	6.4	9.6	12.8	4.5	6.4	9.6	12.8
WKC 15	0.3	33	2.5	3.5	5.3	7.0	2.8	4.0	6.0	8.0	2.8	4.0	6.0	8.0
	0.4	51	3.1	4.4	6.6	8.8	3.5	5.0	7.5	10.0	3.5	5.0	7.5	10.0
	0.8	159	5.4	7.7	11.5	15.3	6.1	8.7	13.1	17.4	6.1	8.7	13.1	17.4
	1.2	323	7.3	10.4	15.6	20.8	8.3	11.8	17.7	23.6	8.3	11.8	17.7	23.6
	1.6	543	8.6	12.3	18.5	24.6	9.8	14.0	21.0	28.0	9.8	14.0	21.0	28.0
WKC 20	0.7	36	4.6	6.6	9.9	13.2	5.3	7.5	11.3	15.0	5.3	7.5	11.3	15.0
	1.0	63	6.2	8.8	13.2	17.6	7.0	10.0	15.0	20.0	7.0	10.0	15.0	20.0
	1.5	123	8.6	12.3	18.5	24.6	9.8	14.0	21.0	28.0	9.8	14.0	21.0	28.0
	2.0	201	11.1	15.8	23.8	31.7	12.6	18.0	27.0	36.0	12.6	18.0	27.0	36.0
	2.7	343	13.4	19.2	28.8	38.4	15.3	21.8	32.7	43.6	15.3	21.8	32.7	43.6
WKC 45	1.4	32	9.2	13.6	20.7	27.3	10.5	15.5	23.5	31.0	10.5	15.5	23.5	31.0
	2.0	60	2.8	18.9	28.2	37.8	14.5	21.5	32.0	43.0	14.5	21.5	32.0	43.0
	3.0	125	17.6	26.4	40.5	52.8	20.0	30.0	46.0	60.0	20.0	30.0	46.0	60.0
	4.0	213	22.0	33.4	50.2	66.9	25.0	38.0	57.0	76.0	25.0	38.0	57.0	76.0
	5.0	324	25.5	39.6	59.0	79.2	29.0	45.0	67.0	90.0	29.0	45.0	67.0	90.0
	5.4	375	27.3	41.4	61.6	82.7	31.0	47.0	70.0	94.0	31.0	47.0	70.0	94.0

Pressure drop data at  $T_{w,in} = 20\text{ °C}$ ; performance data at  $t_c = 45\text{ °C}$

## Evaporators WKE

Example: Refrigerant: R134a;  $t_0 = 0\text{ °C}$ ;  $x = 20\%$ ;  $\Delta t_{\text{sup\_evp}} = \text{ca. } 5\text{ K}$

Heating medium: water;  $w \approx 0,5$  bis  $2\text{ m/s}$

Type	$\dot{V}$	$\Delta p$	$Q_0\text{R134a}$				$Q_0\text{R404A/R507}$				$Q_0\text{R410A}$			
$\Delta t_0\text{ [K]}$			6,0	9,0	12,0	15,0	6,0	9,0	12,0	15,0	6,0	9,0	12,0	15,0
Unit	$\text{m}^3/\text{h}$	mbar	kW	kW	kW	kW	kW	kW	kW	kW	kW	kW	kW	kW
WKE 10	0.4	56	1.5	2.2	3.4	4.2	2.0	2.9	4.5	5.6	1.8	2.7	4.2	5.2
	0.6	108	1.9	2.9	4.4	5.5	2.6	3.9	5.9	7.4	2.4	3.6	5.5	6.9
	0.8	177	2.4	3.6	5.2	6.5	3.2	4.8	7.0	8.8	3.0	4.5	6.5	8.2
	1.0	263	2.9	4.4	6.0	7.5	3.9	5.9	8.0	10.0	3.6	5.5	7.5	9.4
	1.2	364	3.2	4.9	6.8	8.5	4.3	6.5	9.1	11.3	4.0	6.0	8.4	10.6
	1.4	483	3.5	5.2	7.5	9.3	4.6	7.0	10.0	12.5	4.3	6.5	9.3	11.6
	1.6	617	3.7	5.5	8.2	10.2	4.9	7.4	10.9	13.6	4.6	6.9	10.2	12.7
WKE 16	1.0	65	2.5	4.2	6.1	9.0	3.4	5.6	8.2	12.1	3.2	5.3	7.6	11.2
	1.5	126	3.5	5.9	8.5	10.6	4.7	7.9	11.4	14.2	4.4	7.3	10.6	13.2
	2.0	206	4.3	7.1	10.3	12.5	5.8	9.5	13.8	16.7	5.4	8.8	12.9	15.6
	2.5	306	4.9	8.5	11.8	13.8	6.6	11.3	15.8	18.4	6.1	10.6	14.7	17.2
	3.0	424	5.5	9.2	12.8	15.3	7.3	12.4	17.1	20.5	6.8	11.5	15.9	19.1
	3.5	562	5.6	9.5	13.4	16.7	7.5	12.8	17.9	22.4	7.0	11.9	16.7	20.8
WKE 24	1.5	58	3.7	6.9	9.4	13.2	4.9	9.2	12.6	17.6	4.6	8.5	11.7	16.4
	2.0	95	4.3	7.9	11.1	15.4	5.8	10.6	14.8	20.6	5.4	9.9	13.8	19.2
	2.5	141	5.0	9.0	12.6	17.6	6.7	12.1	16.9	23.6	6.2	11.2	15.7	22.0
	3.0	195	5.5	9.9	14.2	19.3	7.4	13.3	19.0	25.8	6.9	12.4	17.7	24.0
	3.5	258	6.2	10.9	15.6	20.8	8.2	14.5	20.9	27.8	7.7	13.5	19.5	25.9
	4.0	330	6.5	11.6	17.0	22.5	8.8	15.6	22.8	30.1	8.2	14.5	21.2	28.0
WKE 44	4.5	410	6.9	12.2	18.3	23.4	9.3	16.4	24.5	31.3	8.6	15.3	22.8	29.2
	2.0	58	6.2	13.1	16.5	19.9	8.2	17.5	22.0	26.6	7.7	16.3	20.5	24.8
	3.0	120	8.4	15.8	20.8	27.0	11.2	21.1	27.8	36.1	10.5	19.7	25.9	33.6
	4.0	205	10.3	17.7	24.6	32.1	13.8	23.7	33.0	43.0	12.9	22.1	30.7	40.0
	5.0	311	12.0	20.0	28.0	36.6	16.1	26.8	37.5	48.9	15.0	25.0	34.9	45.6
	6.0	440	13.4	21.9	31.0	41.1	17.9	29.3	41.4	55.0	16.7	27.3	38.6	51.3
	7.0	590	14.6	23.3	33.6	34.6	19.5	31.1	44.9	58.3	18.1	29.0	41.9	54.3

Pressure drop data at  $T_{w\_in} = 20\text{ °C}$ ; performance data at  $t_0 = 0\text{ °C}$

Legend		
$Q_{c\_nom}$	[kW]	Condenser performance under nominal conditions
$Q_{0\_nom}$	[kW]	Evaporator performance under nominal conditions
$\Delta t_{\text{sub}}$	[K]	Subcooling of the refrigerant in the condenser
$\Delta t_{\text{sub\_evp}}$	[K]	Superheating of the suction vapour
$\Delta t_c$	[K]	$t_c - t_{w\_in}$ temperature difference in the condenser
$\Delta t_0$	[K]	$t_{w\_in} - t_0$ temperature difference in the evaporator
$t_0$	[°C]	Evaporation temperature of the refrigerant at the evaporator outlet
$t_c$	[°C]	Condensation temperature of the refrigerant in the condenser
$t_{\text{sup}}$	[°C]	Temperature of the hot gas refrigerant
$t_{w\_in}$	[°C]	Water temperature at the inlet
$\dot{V}$	[ $\text{m}^3/\text{h}$ ]	Water volume flow
$w$	[m/s]	Water velocity
$x$	[-]	Vapour quality at the evaporator inlet
$\Delta p$	[mbar]	Pressure drop

## Contact us

Wieland Thermal Solutions | [wieland.com](https://www.wieland.com)

**P** +49 731 944 1017 **@** [thermalsolutions@wieland.com](mailto:thermalsolutions@wieland.com)



**wieland**

Wieland-Werke AG | Graf-Arco-Straße 36 | 89079 Ulm | Germany  
[info@wieland.com](mailto:info@wieland.com) | [wieland.com](https://www.wieland.com)

This printed matter is not subject to revision. No claims can be derived from it unless there is evidence of intent or gross negligence.  
The product characteristics are not guaranteed and do not replace our experts' advice.